



Forward. For all.

KULI Overview KULI软件概述

Endre Németh, Account Manager KULI Sales



BODY EXTERIORS & STRUCTURES

SEATING SYSTEMS

POWER & VISION

COMPLETE VEHICLES

NEW MOBILITY

BODY & CHASSIS

EXTERIORS

SEATING

POWERTRAIN

ELECTRONICS

MECHATRONICS,
MIRRORS, LIGHTING

COMPLETE
VEHICLES

NEW MOBILITY

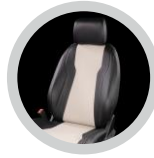

Engineering Center Steyr
St. Valentin, Austria



Vehicle Engineering



Propulsion Engineering

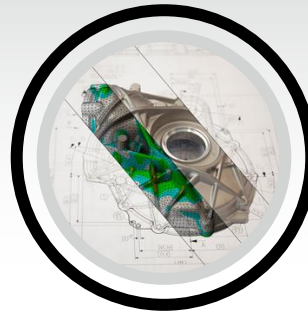

**Simulation Services
& Software**



Testing Services



Low Volume
Production



**KULI is an industry standard Windows desktop software for
1D simulation of vehicle thermal management**

**KULI 是一款工业标准的 Windows 桌面软件，适用于
车辆热管理一维仿真**

Our KULI Team



Christian Rathberger
Sr. Manager VTM Software & IoT



Endre Németh
Account Manager KULI Sales



Christoph Stroh
Manager KULI Methods



Thomas Naderhirn
Manager KULI Software Dev.



Idea to Simulation
仿真实现



Accurate Results
精准结果



Technical Support
技术支持

Driving User Satisfaction

What KULI
offers.

Your benefits 应用范围

Thermal management for passenger cars, trucks, trains, construction and farm machines and other industrial applications.
乘用车、商用车、火车、建筑和农用机械，以及其他工业应用。

Save time & costs 节省时间和成本

Reduce development time and costs compared to bench testing.
相比台架试验，节省开发时间和成本。

Fast calculation time 快速计算

Quick evaluation of component interactions.
快速评估零部件之间的相互影响

Modular design 模块化设计

Choose only the appropriate KULI Modules for your task.
选择您适用的KULI模块

Start now 零学习成本

Easy to use after one-day training.
仅需一天培训就可以使用

KULI modules



KULI hvac

A/C and Heat Pump
System Development
空调及热泵系统开发



KULI base

All your Basic Needs for
Steady State Cooling System Design
基础稳态冷却系统设计

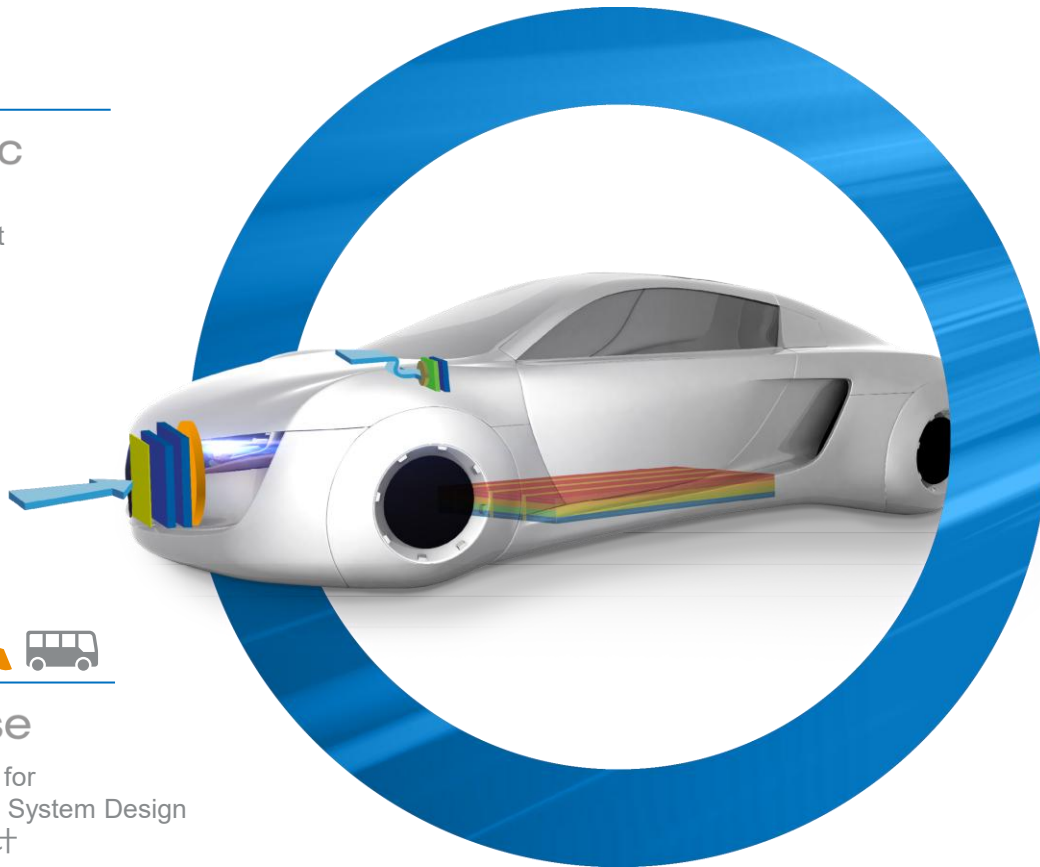

KULI drive

Drive Cycles and Engine Model
驾驶循环及发动机模型



KULI eco

EV Battery to Powertrain
动力电池



KULI advanced

Interfaces, CFD and Optimization
接口、CFD及优化

1D thermal management — 一维热管理



Understand All VTM

System Key Properties:

用于理解所有热系统关键属性



HVAC
System

- Temperatures 温度
- Pressure Levels 压力
- Mass Flow Distribution 流量
- Heat- & Energy Flows 热量及能量
- Passenger Comfort 乘员舱舒适性
- Control Strategies 控制逻辑

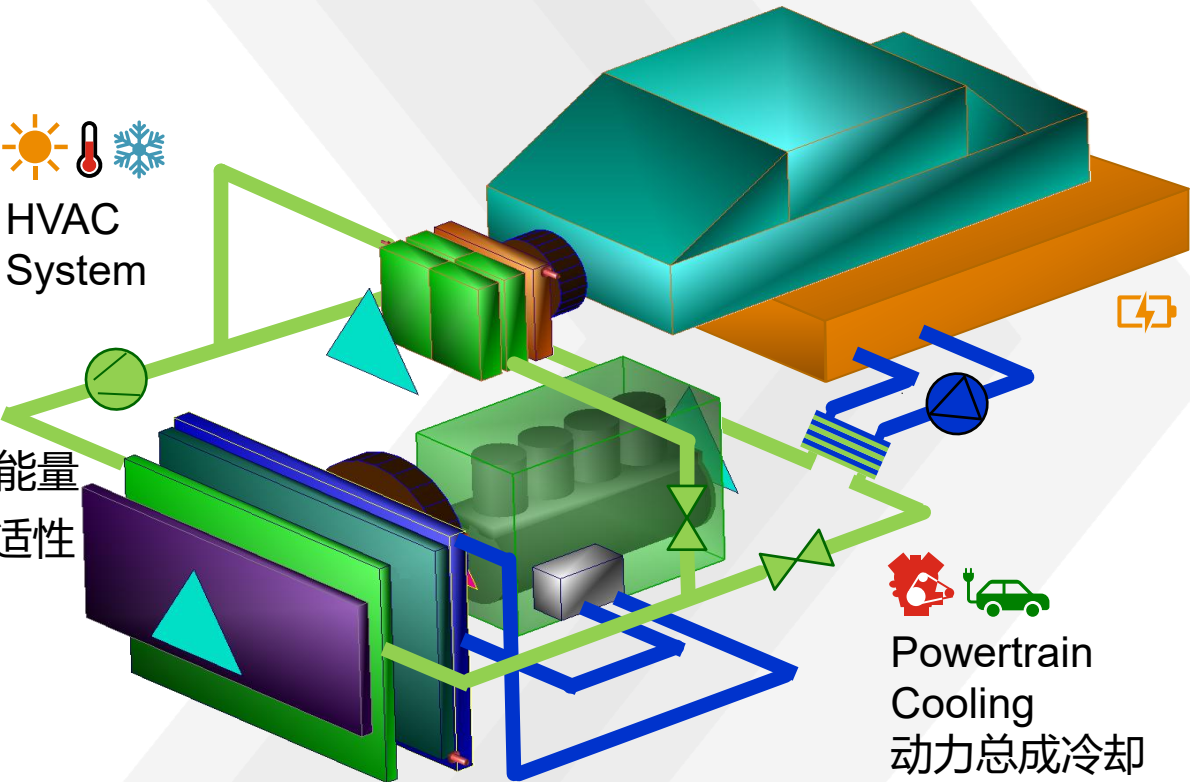

Powertrain
Cooling
动力总成冷却

Component understanding 理解零部件

- Select the right heat exchangers for your specific tasks 选择合适的热交换器
- Run heat exchangers in their most efficient operating points 在最高效率点使用热交换器
- Prevent overheating of powertrain components and batteries 防止动力总成零部件及电池过热
- Track problems to their roots 寻找问题本质

System understanding 理解系统

- Assemble components to a perfect system 将零部件集成为一个完美系统
- Understand cooling- and HVAC system interactions 理解冷却系统和空调系统相互影响
- Understand system benefits of new components or technologies 理解新部件或技术在系统中的收益
- Support virtual controller development 支持虚拟控制器开发
- Optimize drive cycle range and comfort 优化行驶里程及舒适性

OEMs 主机厂

KULI allows you to optimize both vehicle **performance** and **efficiency** under the tight time constraints of modern development processes.

KULI将帮助您在现代化开发流程的紧迫时间限制下
快速优化车辆表现和效率

Suppliers 供应商

KULI allows you to understand the **requirements** and **benefits** of your component and gives you a powerful sales pitch at OEMs.

KULI将帮助您理解零部件的要求和产品优势，
并助力您在主机厂的销售。

KULI workflow KULI工作流程



- Input data (Geometry, Characteristic)
输入数据 (几何数据、特性参数)
- Save in Component Library
保存到零部件数据库中

- Load components (from Library)
(从数据库) 调取零部件
- Define Media Properties
定义媒介属性
- Position and Connect Components
零部件位置和连接
- Input Simulation Parameters
输入仿真参数

- Run Analysis
运行分析
- Optimize, Vary Parameters
优化、调整参数

- Get Output from Postprocessor, Excel Sheet, ...
从后处理器、Excel获得输出结果
- Compare with System Measurement Data
与测试结果进行比较
- Interpret Results, Reporting
解释结果、生成报告

Typical applications 典型案例

Concept studies 概念分析



- Find the best architecture and components for your application!
寻找最佳的系统架构和零部件

- The later a design change is made the more expensive it is...
后期的设计变更将导致高昂的成本

Simulation saves you time and money!
仿真计算将节约您的时间和投入!

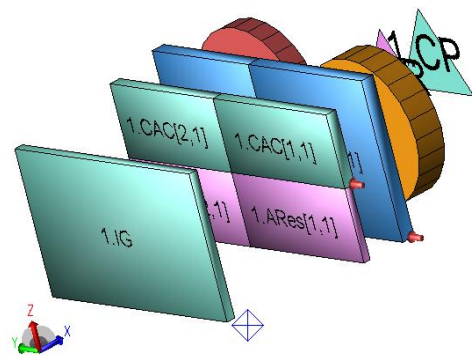
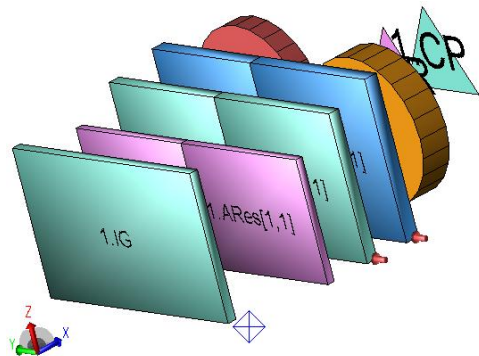
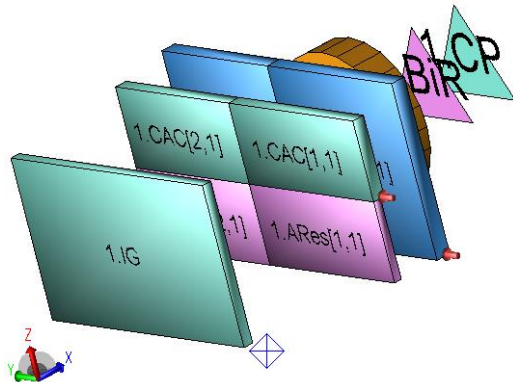
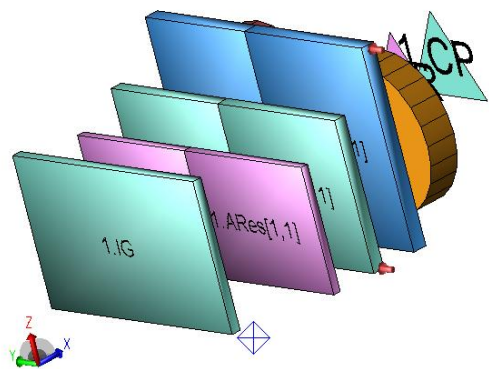

Top-tank temperature 上水箱温度

Simulation parameters

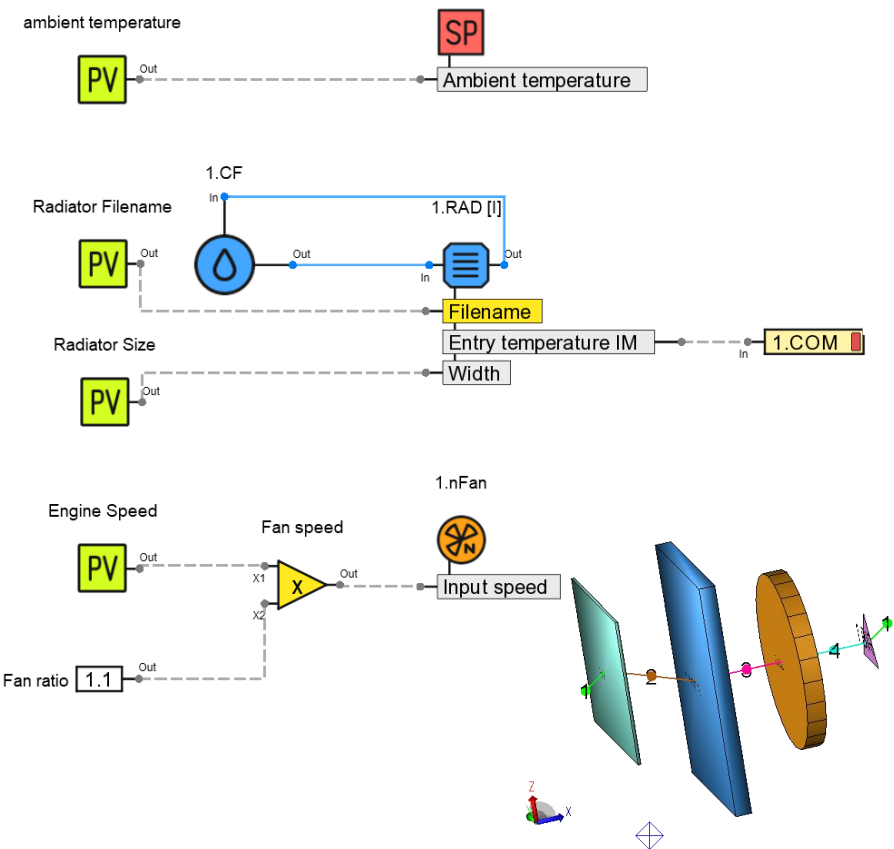

Input 输入参数

- KULI data for fans and coolers
KULI风扇和冷却器参数
- Volume flow data for all participating fluids
相关流体的质量流量
- Ambient temperature 环境温度
- Driving velocity 行驶速度
- Rejected heat by the condenser 冷凝器换热量
- Amount of glycol in the coolant 冷却液乙二醇比例

Results 结果

- Top tank temperature 上水箱温度
- Air to boil 适用环境温度
- Analysis of the operating points of the fans/ coolers
风扇及换热器工况分析
- Parameter variation (fan speeds, volume flows, ...) on the above-mentioned measurable variables
基于上述测试变量的变参数分析 (风扇转速、体积流量.....)

Minimize package size with optimization 优化前端模块尺寸

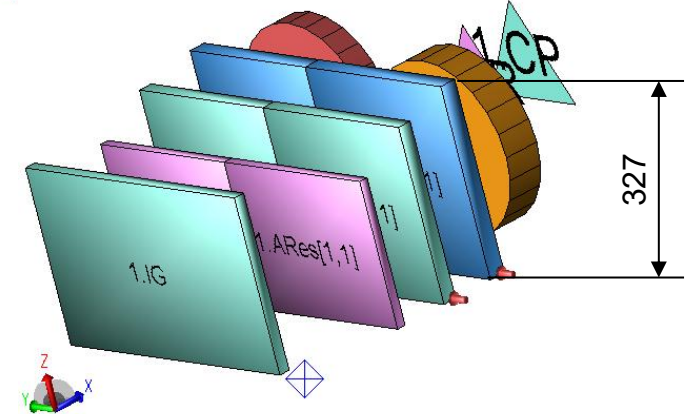
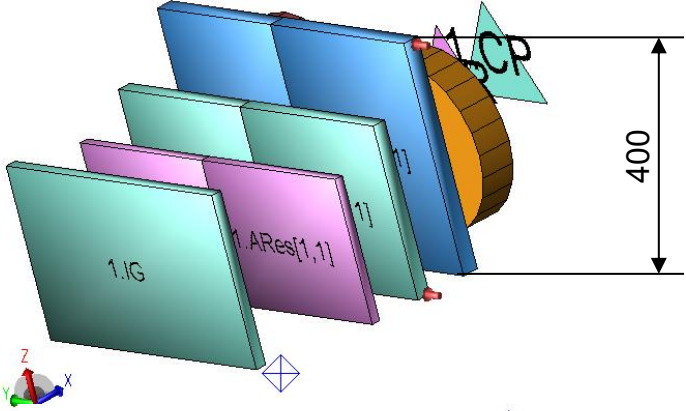

Simulation parameters

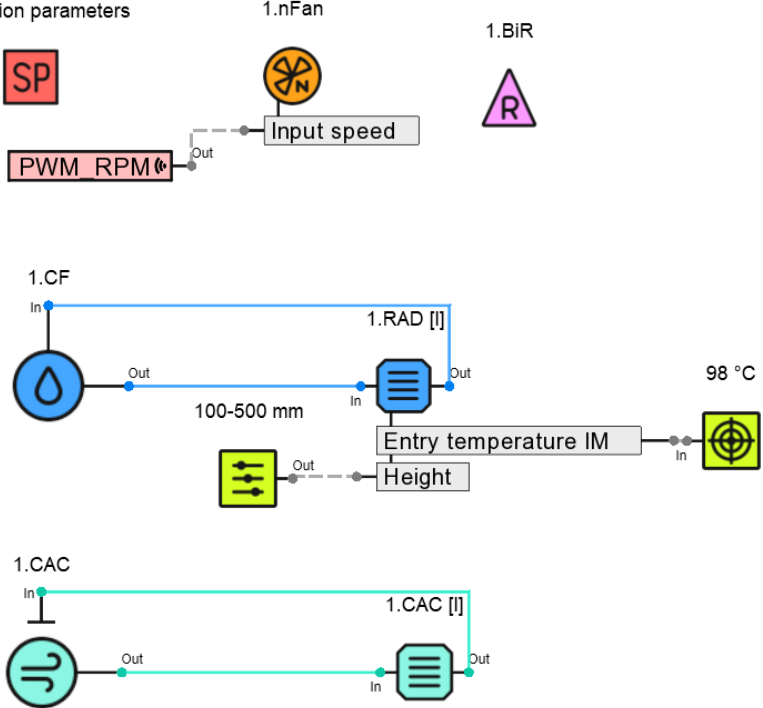

HVAC simulation 空调系统仿真



- Develop efficient cooling and heating solutions!
开发高效冷却和采暖方案!

- EV HVAC systems can reduce winter range by 30-50% and summer range by >20%
对于电动车空调，空调系统可能在冬天降低行驶里程30-50%，在夏天降低超过20%

Simulation ensures sustainable passenger comfort!
仿真计算将保证可持续的乘员舱舒适性!

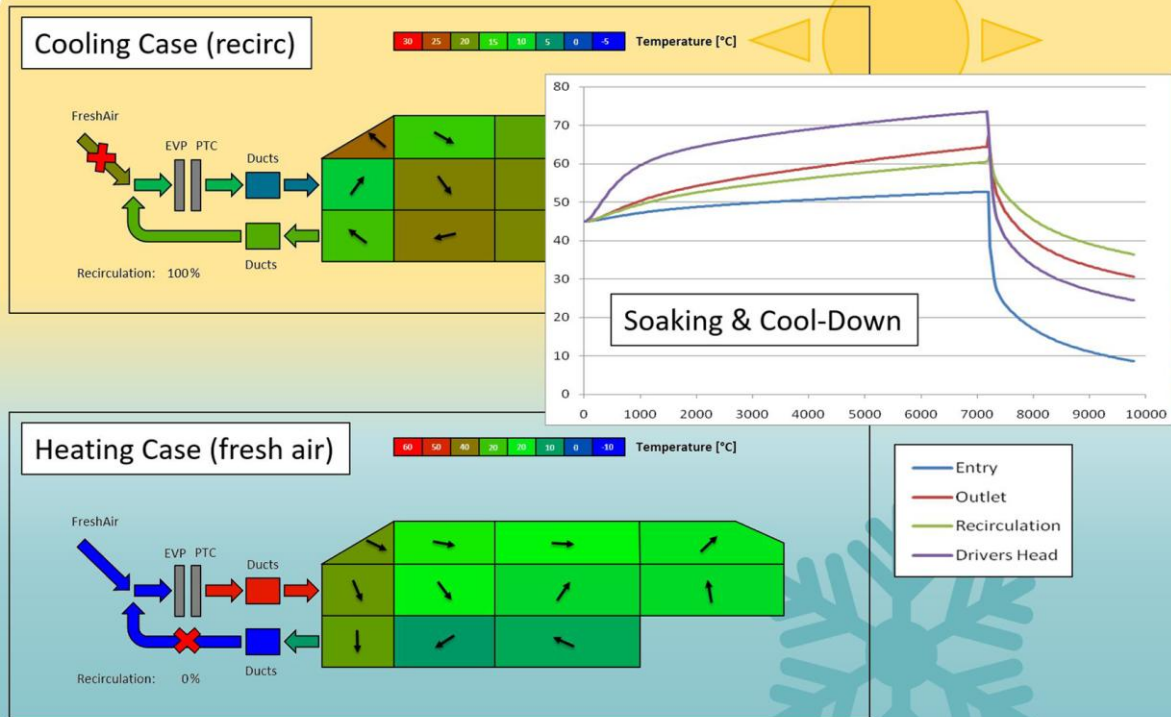

Complete VTM simulation 整车热管理系统仿真

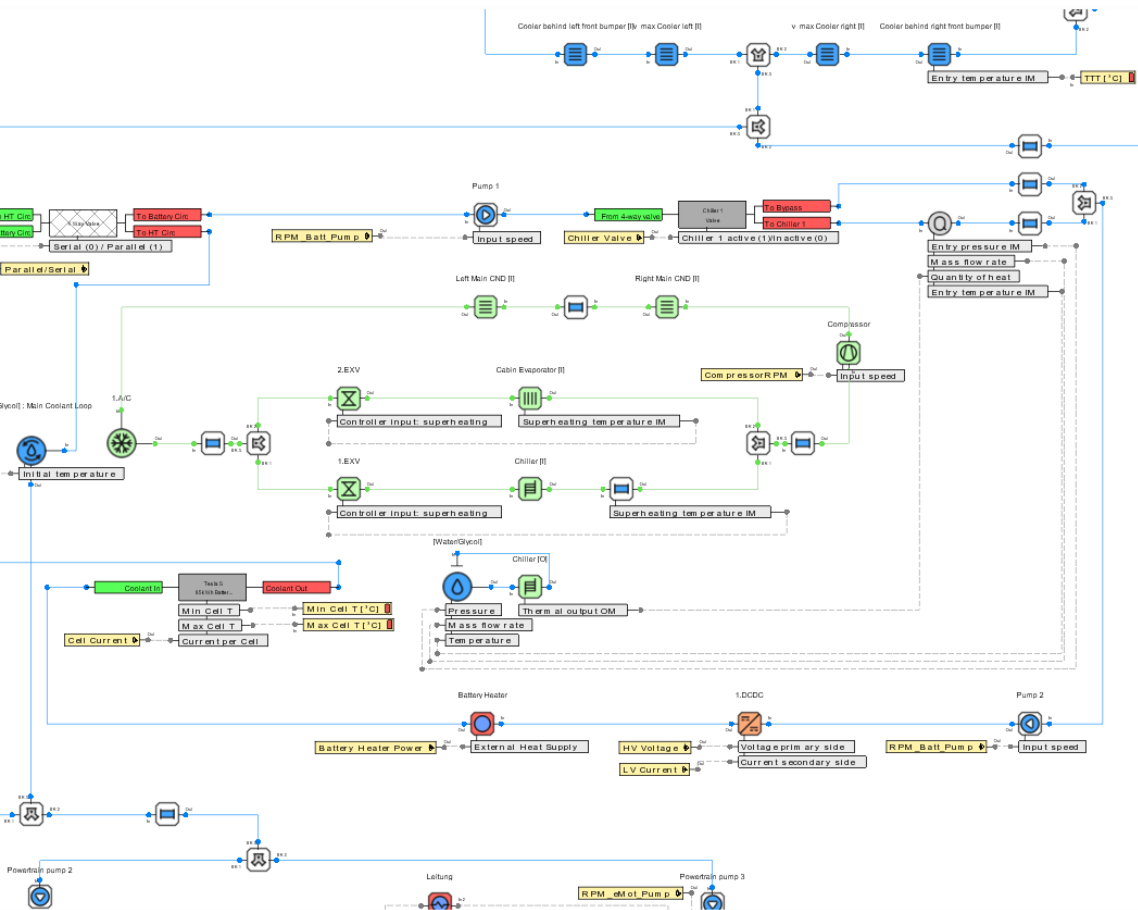

- Understand your complete system with all relevant pressure interactions
理解系统及其相互影响

- There is no system optimization without system understanding
理解并优化系统表现

**Simulation improves vehicle efficiency!
仿真计算提升车辆效率!**

KULI GUI 用户界面



Project Organization
项目组织

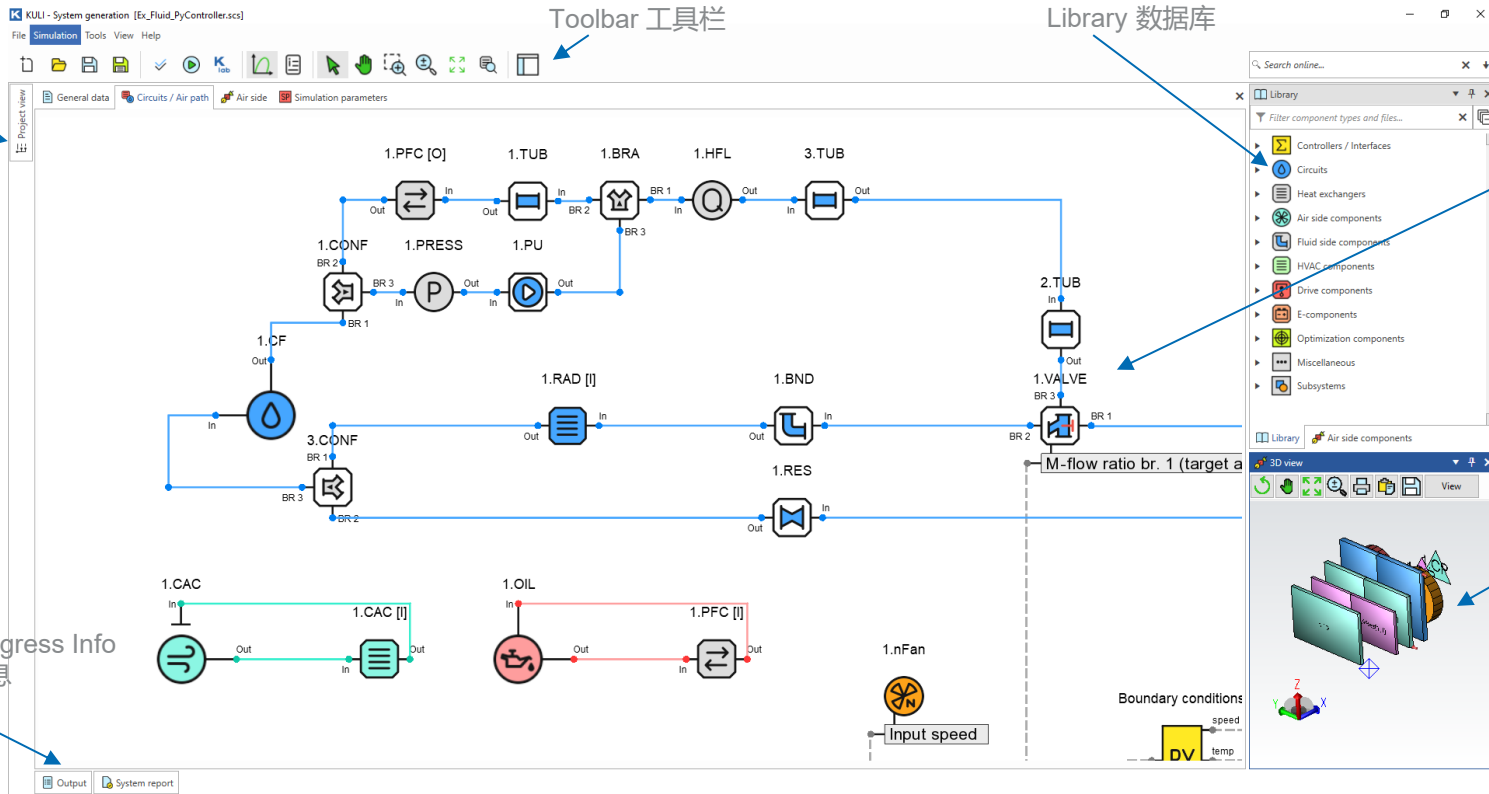

Analysis Progress Info
分析进度信息

Library 数据库

2D Fluid
Network View
二维流体
管路视图

3D Air
Network View
三维空气
视图

KULI lab GUI 后处理器界面



Function toolbar

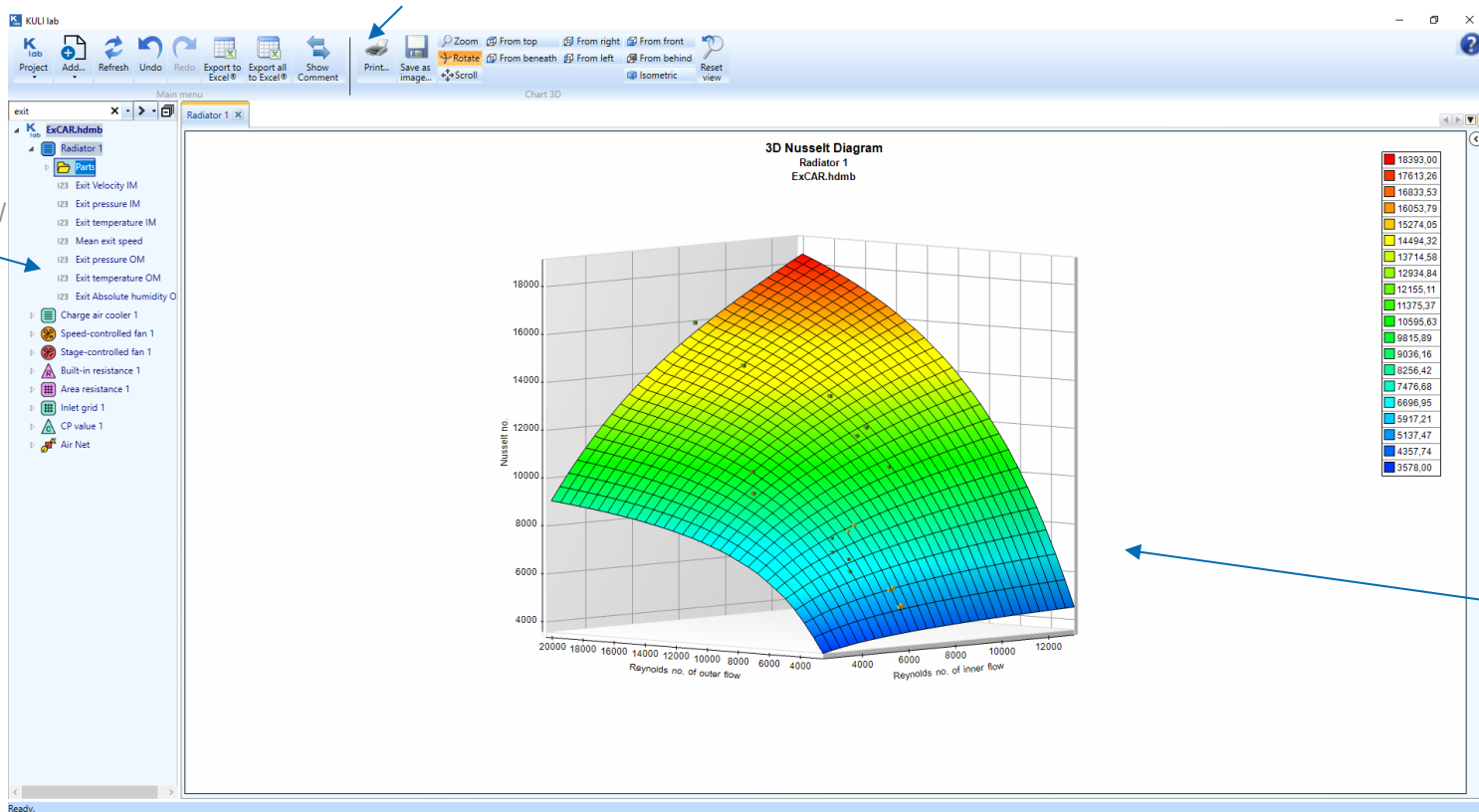

Components /
Properties
零部件/属性

Simulation
results
仿真计算结果

Global KULI contacts 联系方式



Albert Türtscher North America

AT engineering LLC
PO Box 18962
Golden, CO 80402, USA
albert.tuertscher@at-cae.com
+1 734 276 5516

Valmir Fleischmann South America

VirtualCAE
Rua Tiradentes 160 - Sala 22, São Caetano
do Sul, São Paulo (CEP 09541-220), Brazil
vendas@virtualcae.com.br
+55 11 4229 1349

Endre Németh Europe

Magna Powertrain
Engineering Center Steyr GmbH & Co KG
Steyrer Straße 32
4300 St. Valentin, Austria
endre.nemeth@magna.com
+43 664 78708988

Rajeev Gopalakrishnan India

MAXrad SOFTWARE (India) Pvt. Ltd.
No 17, B Main, 34th Cross, No 1542,
Varada, 1st Stage, 5th Block, HBR Layout,
Bangalore KA 560043, India
rajeev@maxsoft-india.com
+91 8049 144149

Terra Cai China

Shanghai Intelligent Thermal Technology Co., Ltd.
Building C, No. 888 Huanhu West Second Road,
Lingang New Area, China (Shanghai) Pilot Free
Trade Zone 201306
terra.cai@thermtec.com
+86 21 5077 9790

Jin Seok South Korea

TAE SUNG S&E Inc.
Seoulforest Kolon Digital Tower II 10F
Seongsu-dong2-ga, Seongdong-gu,
133-120, Seoul, South Korea
jseok@tsne.co.kr
+82 2 3431 2442

Toshihiro Senzoku Japan

Chuozen Co., Ltd
15-20 Furuwatari-cho, Naka-ku, Nagoya
Aichi 460-025, Japan
senzuko-t@chuozen.co.jp
+81 52 323 1006

A blurred image of a white car driving on a road, with red light trails indicating motion. The background is a hazy, open landscape under a bright sky.

KULI software

Visit our [website](#) for further information!



Forward. For all.